

Released 2008
Achievement Test

Science

GRADE

9

we educate
éduquer

This document contains a full release of test items from the 2008 Grade 9 Science Achievement Test.

Released test items, which contained approximately 25% of the total number of test items from previously secured achievement tests, were mailed to school administrators each fall from 2004 to 2006 and have been made available to teachers only in print form because of copyright limitations. **Every second year**, as of the fall of 2007, **a complete test** for all achievement test subjects and grades (except Grades 6 and 9 Social Studies; Grades 3, 6, and 9 Français/French Language Arts; and Grade 9 Knowledge and Employability courses) will be **mailed** to school administrators in conjunction with the assessment highlights report for that year. In this way, teachers will receive complete forms of achievement tests. The parts of those tests that are released in print form for which electronic copyright permission is received will subsequently be posted on the Alberta Education website. A test blueprint and an answer key that includes the difficulty, reporting category, language function, and item description for each test item will also be included. These materials, along with the Program of Studies and subject bulletin, provide information that can be used to inform instructional practice.

Assessment highlights provide information about the overall test, the test blueprints, and student performance on the English form of the Science Achievement Test in Grade 9. Also provided is commentary on student performance at the *acceptable standard* and the *standard of excellence* on selected items from the 2009 Achievement Test. This information is intended for teachers and is best used in conjunction with the multi-year and detailed school reports that are available to schools via the extranet.

Assessment highlights reports for all achievement test subjects and grades (except Grades 3, 6, and 9 Français/French Language Arts; and Grade 9 Knowledge and Employability courses) will be **posted on the Alberta Education website every year** in the fall.

For further information, contact Sean Wells, Grades 6 and 9 Science Examination Manager, at Sean.Wells@gov.ab.ca, or Jo-Anne Hug, Director, Achievement Testing, at Jo-Anne.Hug@gov.ab.ca at Learner Assessment, or call (780) 427-0010. To call toll-free from outside Edmonton, dial (780) 310-0000.

The Alberta Education Internet address is education.alberta.ca.

Copyright 2009, the Crown in Right of Alberta, as represented by the Minister of Education, Alberta Education, Learner Assessment, 44 Capital Boulevard, 10044 108 Street NW, Edmonton, Alberta T5J 5E6, and its licensors. All rights reserved.

Special permission is granted to **Alberta educators only** to reproduce, for educational purposes and on a non-profit basis, parts of this document that do **not** contain excerpted material.

Excerpted material in this document **shall not** be reproduced without the written permission of the original publisher (see credits, where applicable).

2008 Achievement Test Questions

The questions presented in this document are from the previously secured 2008 Grade 9 Science Achievement Test and are representative of the questions that form achievement tests. These questions are released by Alberta Education for teacher and student use.

Grade 9 Achievement Test

2008

Science

1. One **advantage** of asexual reproduction is that it
- A. leads to greater variation within a species
 - B. allows offspring to adapt to environmental changes quickly
 - C. leads to long-term bonds between the offspring and the parent
 - D. allows a population to grow substantially over a short period of time

Use the following flow chart to answer question 2.

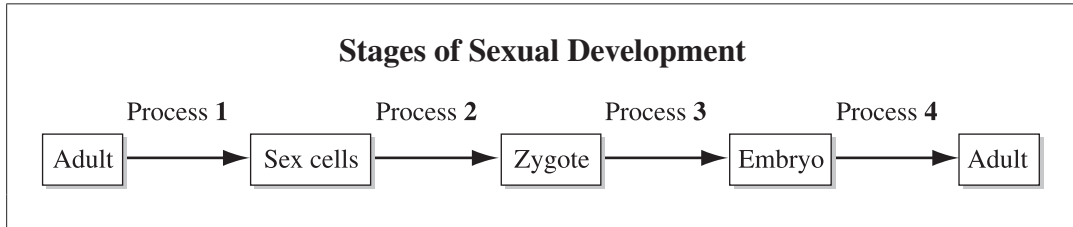

2. In the flowchart above, the stage at which fertilization takes place is labelled
- A. Process 1
 - B. Process 2
 - C. Process 3
 - D. Process 4
-

Use the following information to answer question 3.

- Wolves prey on elk.
- Elk consume willow shrubs.
- Willow shrubs along stream banks provide shade.
- Bull trout require cool water temperatures.

3. Which of the following changes is **most likely** to occur as a result of a decreased wolf population?
- A. A decreased number of elk
 - B. A decreased number of bull trout
 - C. An increased number of willow shrubs
 - D. An increased number of predators of wolves

Use the following information to answer question 4.

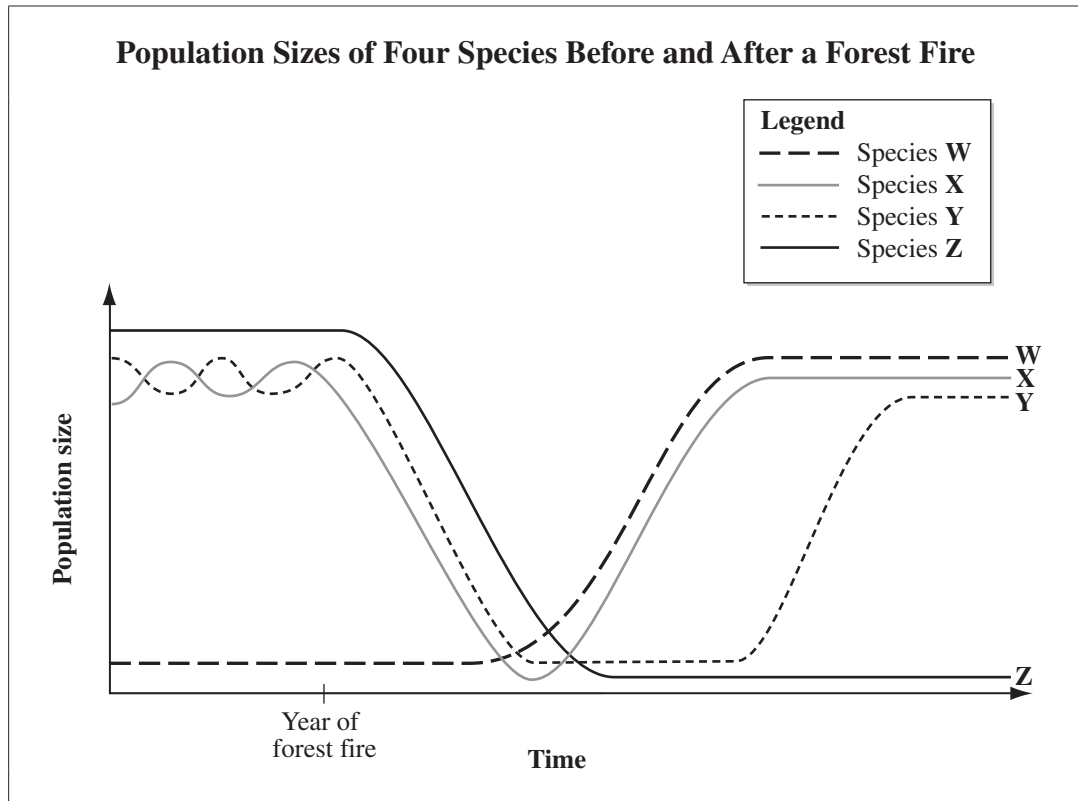

4. Given the trends on the graph shown above, which species has the broadest niche?

- A. W
- B. X
- C. Y
- D. Z

5. Which of the following human traits is influenced by environmental factors?

- A. Mass
- B. Blood type
- C. Colour-blindness
- D. Ability to roll tongue

Use the following information to answer question 6.

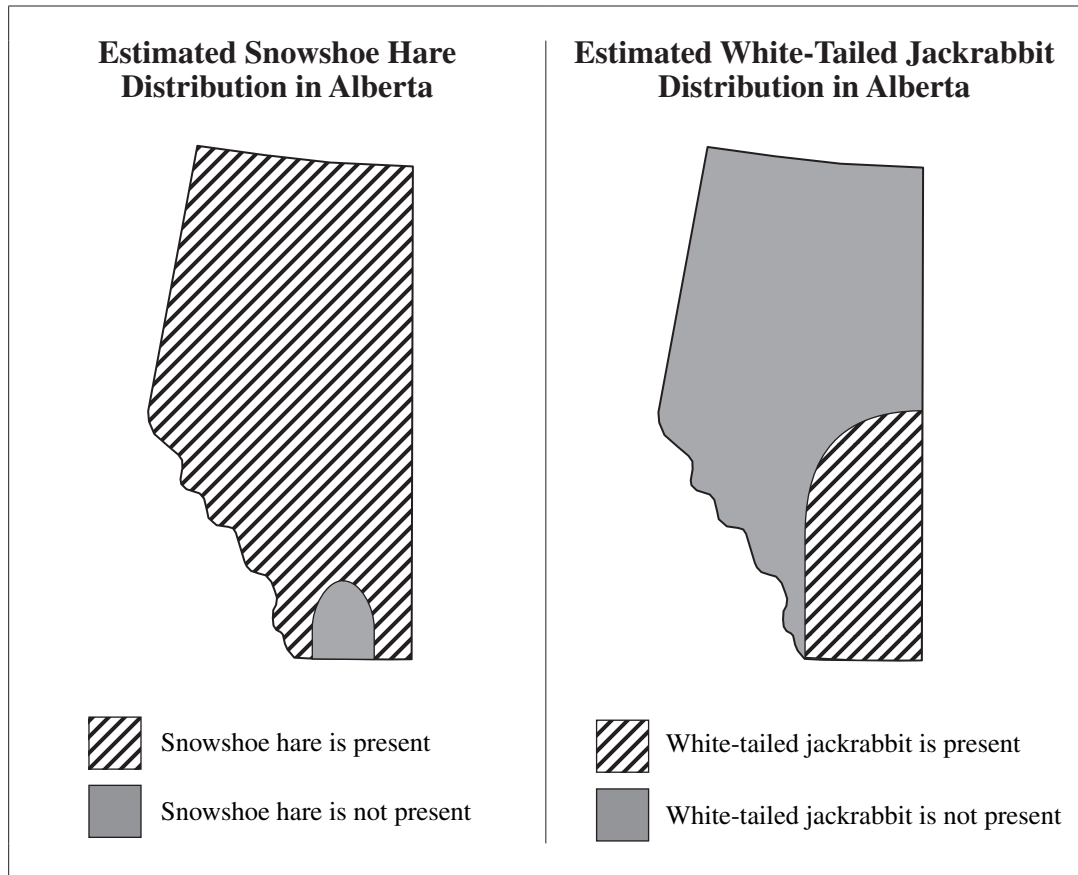

6. According to the information above, the white-tailed jackrabbit has a *i* niche and is a better example of a *ii* species than the snowshoe hare.

The statement above is completed by the information in row

Row	<i>i</i>	<i>ii</i>
A.	broader	generalist
B.	broader	specialist
C.	narrower	generalist
D.	narrower	specialist

Use the following map to answer question 7.



7. Which of the following countries contains the **most** biological diversity?
- A. United States
 - B. Argentina
 - C. Canada
 - D. Brazil

Use the following information to answer question 8.

A man and a woman who both have brown hair have three children. Two of the children have brown hair and one child has blonde hair.

The gene that codes for brown hair (B) is dominant to the gene that codes for blonde hair (b).

8. The gene pair combinations of the man and the woman are **most likely**

- A. bb and bb
 - B. Bb and Bb
 - C. BB and Bb
 - D. BB and BB
-

9. Which part of a cell carries information about heritable traits?

- A. A cell wall
- B. A chloroplast
- C. A chromosome
- D. A cell membrane

Use the following information to answer question 10.

Human cells normally have 46 chromosomes. Klinefelter syndrome results when human cells have 47 chromosomes.

10. Klinefelter syndrome is the result of a defect that occurs during

- A. mitosis
- B. meiosis
- C. artificial selection
- D. asexual reproduction

Numerical Response

1. Use the following code to indicate the type of variation that is associated with each of the human traits listed below.

1 = Discrete variation

2 = Continuous variation

Variation: _____

Trait: **Gender**

Height

Hand size

(Record all **three digits** of your answer in the numerical-response section on the answer sheet.)

11. In most corrosion and combustion reactions, *i* is a *ii* .

The statement above is completed by the information in row

Row	<i>i</i>	<i>ii</i>
A.	oxygen	reactant
B.	oxygen	product
C.	water	reactant
D.	water	product

Use the following table to answer question 12.

Element	Melting Point (°C)	Boiling Point (°C)	Colour	Conductivity	Malleability
1	962	2 162	Lustrous silver	Good conductor	Very malleable
2	-218	-183	Colourless	Good insulator	Not malleable
3	115	445	Yellow	?	Not malleable
4	1 064	2 856	Lustrous yellow	?	Very malleable

12. Which of the following statements describes the conductivity of elements 3 and 4?

- A. Both elements are good insulators.
- B. Both elements are good conductors.
- C. Element 3 is a good conductor and element 4 is a good insulator.
- D. Element 3 is a good insulator and element 4 is a good conductor.

13. What is the chemical name of a molecular substance that is composed of one carbon atom and four chlorine atoms?

- A. Carbon tetrachlorine
- B. Carbon tetrachloride
- C. Carbon chlorine
- D. Carbon chloride

Use the following information to answer questions 14 and 15.

1 1.01 1+, 1- H hydrogen											2 4.00 He helium				
3 6.94 1+ Li lithium	4 9.01 2+ Be beryllium	5 10.81 B boron	6 12.01 C carbon	7 14.01 3- N nitrogen	8 16.00 2- O oxygen	9 19.00 1- F fluorine	10 20.18 Ne neon	11 22.99 1+ Na sodium	12 24.31 2+ Mg magnesium	13 26.98 3+ Al aluminum	14 28.09 Si silicon	15 30.97 3- P phosphorus	16 32.07 2- S sulfur	17 35.45 1- Cl chlorine	18 39.95 Ar argon

Legend for Elements

Solid	Gas
--------------	------------

Note: The legend denotes the states of elements at a temperature of 25 °C.

Key

Atomic number	3	6.94	Atomic molar mass
		1+	Common ion charges (most common first)
Symbol	Li		
		lithium	Name

14. Which of the following statements about helium, neon, and argon is true?
- They have the same number of protons.
 - They have the same number of neutrons.
 - They are solids at a temperature of 25 °C.
 - They react with other substances in a similar way.
15. Which of the following rows identifies both the elements and number of atoms that are present in one molecule of $C_6H_{12}O_6$?

Row	Elements	Number of Atoms
A.	Carbon, helium, and oxygen	12
B.	Carbon, helium, and oxygen	24
C.	Carbon, hydrogen, and oxygen	12
D.	Carbon, hydrogen, and oxygen	24

16. Which of the following events is an example of a chemical change?

- A. Liquid nitrogen evaporates.
- B. A candle burns.
- C. Water boils.
- D. Ice melts.

17. When two *i* elements are combined, *ii* compound is formed.

The statement above is completed by the information in row

Row	<i>i</i>	<i>ii</i>
A.	metallic	an ionic
B.	metallic	a molecular
C.	non-metallic	an ionic
D.	non-metallic	a molecular

18. Which of the following substances is a solution?

- A. Acid rain
- B. Table salt
- C. Helium gas
- D. Baking soda

Use the following information to answer question 19.

A student tests the reactivity of four metals by placing a piece of each metal into hydrochloric acid. Each piece has an initial mass of 40 g. The student records her observations in the following table.

Metal	Initial acid concentration (g/L)	Temperature of solution after metal reacts with hydrochloric acid (°C)	Mass of metal after it reacts with hydrochloric acid (g)
1	200	28	18
2	200	29	32
3	200	42	14
4	200	35	20

19. The information in the table shows that the metal that reacts **most readily** with hydrochloric acid is
- A. 1
B. 2
C. 3
D. 4

Use the following models to answer question 20.

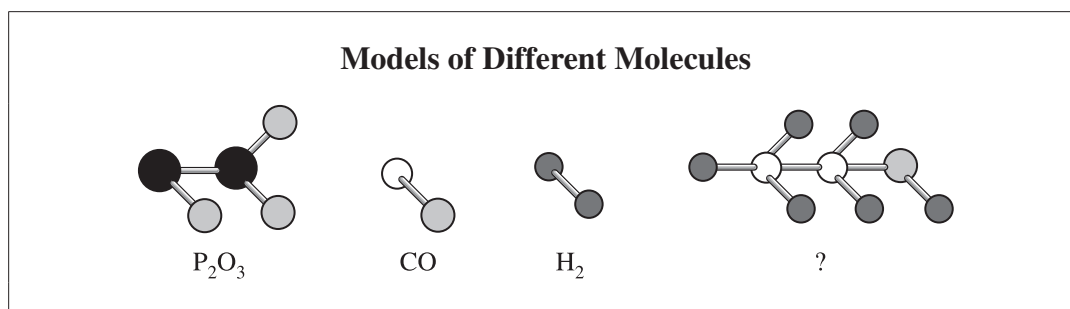

20. The chemical formula for the unknown molecule shown above is
- A. P_2H_5OH
B. P_2H_5CH
C. C_2H_5OH
D. O_2H_5CH

Use the following information to answer numerical-response question 2.

A student burns a piece of magnesium that has a mass of 70.2 g and makes the following observations.

- Heat is generated.
- An intense white light is emitted.
- A mass of 130.8 g of white magnesium oxide ash is produced.

Numerical Response

- 2.** The mass of oxygen that reacts in the chemical reaction described above is _____ g.

(Record your answer in the numerical-response section on the answer sheet.)

21. Which of the following substances is inorganic?
- A. Table salt
 - B. Peanut oil
 - C. Orange juice
 - D. Brown sugar
22. Which of the following statements **best** defines the term LD_{50} ?
- A. LD_{50} is the proportion of the first 50 organisms in a test population that dies when exposed to a particular substance.
 - B. LD_{50} is the proportion of the first 50 organisms in a test population that becomes sick when exposed to a particular substance.
 - C. LD_{50} is the concentration of a substance administered to a test population that kills half the organisms in the test population.
 - D. LD_{50} is the concentration of a substance administered to a test population that makes half the organisms in the test population sick.

Use the following information to answer question 23.

Nitrogen waste from a cattle feedlot enters a nearby lake. A biologist plots the following graph of the population sizes of algae and fish in the lake over time. At point X, the biologist starts to measure the level of dissolved oxygen in the lake.

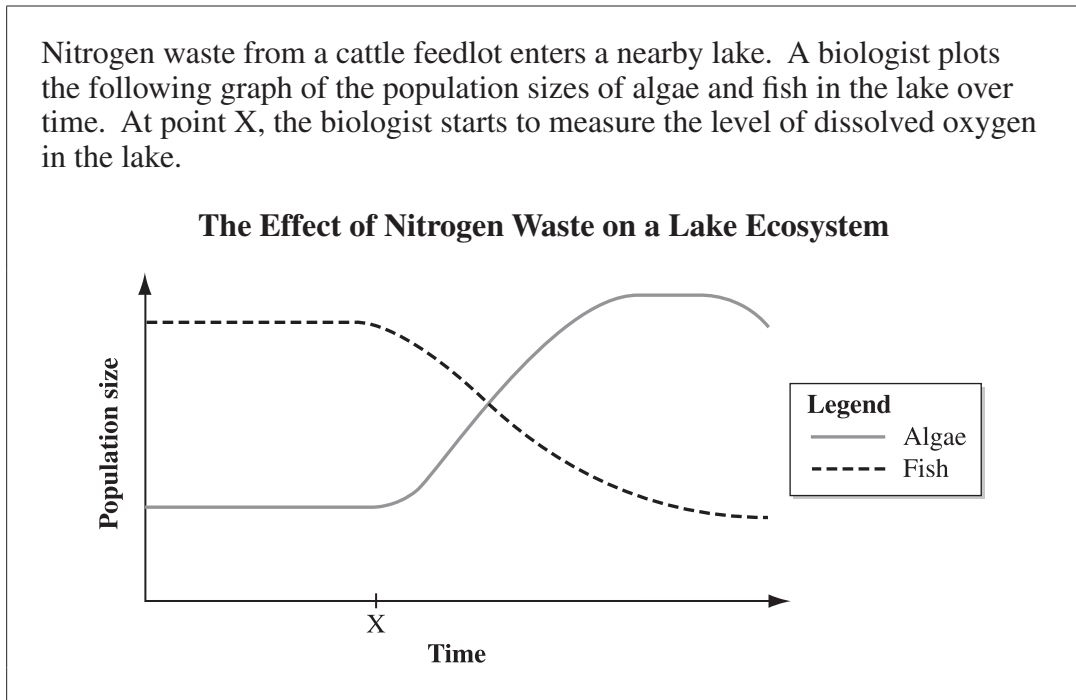

23. Which of the following graphs shows the dissolved oxygen concentration that the biologist measures in the lake?

A.

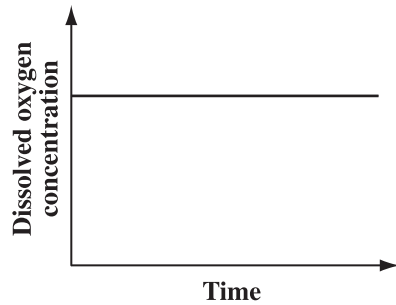

B.

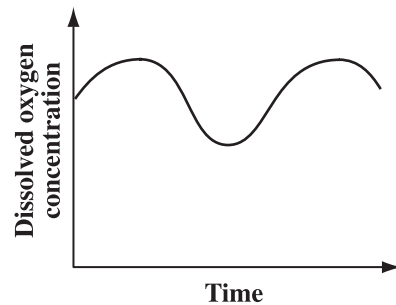

C.

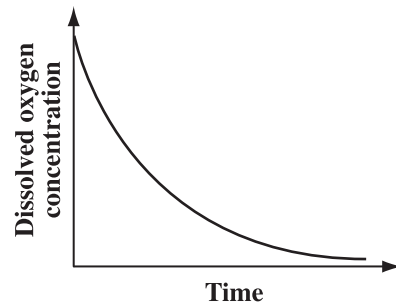

D.

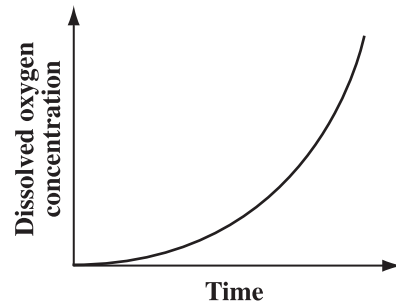

Use the following information to answer questions 24 and 25.

The following three brands of fertilizer are administered to three seedlings in a controlled experiment.

Before the administration of the fertilizers, each seedling had similar root growth and three leaves. None of the seedlings had developed flowers.

Composition of Three Brands of Fertilizer

Brand	Major Components		
	Nitrogen (%)	Phosphorous (%)	Potassium (%)
W	7	15	17
X	10	24	5
Y	13	5	10

At the end of a two-month growth period, the following observations are made.

Characteristics of Three Plants Fertilized with Three Brands of Fertilizer

Plant	Brand of Fertilizer	Number of Flowers	Length of Roots (cm)	Number of Leaves
1	W	15	9	6
2	X	5	14	11
3	Y	10	4	16

24. What is the manipulated variable in the experiment above?
- A. The overall growth of the plants
 - B. The length of time that each plant grows
 - C. The amount of water that the plants receive
 - D. The brand of fertilizer that is used on each plant
25. Which of the following conclusions is supported by the results of the experiment?
- A. Nitrogen promotes leaf growth, and potassium promotes flower growth.
 - B. Nitrogen promotes leaf growth, and potassium promotes root growth.
 - C. Nitrogen promotes root growth, and phosphorous promotes flower growth.
 - D. Nitrogen promotes root growth, and phosphorous promotes leaf growth.

26. Which of the following substances can be synthesized by plants?
- A. Silicon
 - B. Sulfur
 - C. Sugar
 - D. Salt

Use the following information to answer question 27.

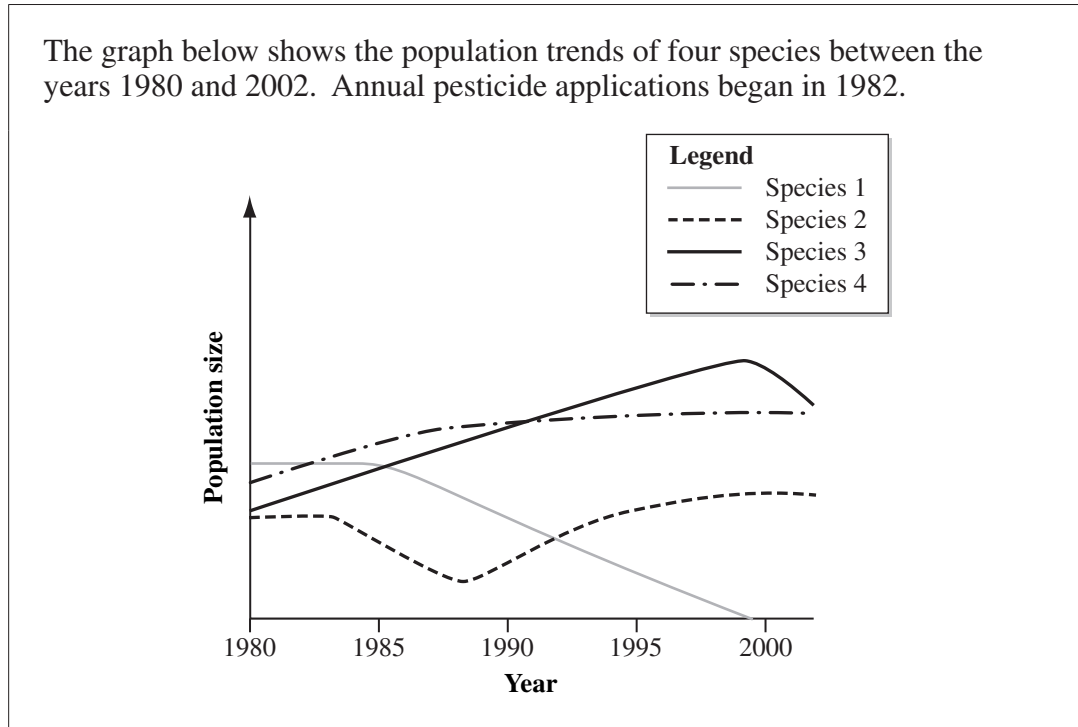

27. Which of the following inferences is supported by the information in the graph above?
- A. Species 1 became resistant to pesticide use.
 - B. Species 2 became resistant to pesticide use.
 - C. Species 3 was affected most by pesticide use.
 - D. Species 4 was affected most by pesticide use.

Use the following information to answer questions 28 to 30.

Many organisms are sensitive to changes in the pH of their environments. The graph below shows the concentrations of organisms of four different species as a function of the pH of a lake.

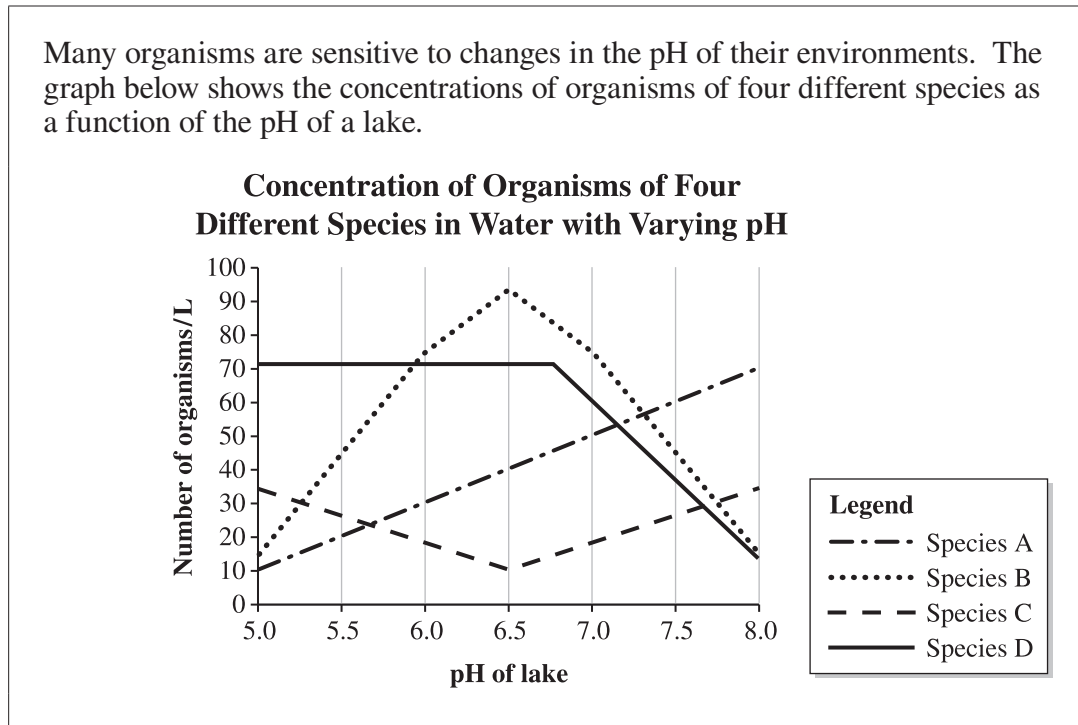

28. According to the information in the graph, which of the species is **most sensitive** to changes in the pH of the lake?
- A. Species A
 - B. Species B
 - C. Species C
 - D. Species D
29. Which species has the **fewest** number of organisms present in lake water that has a neutral pH?
- A. Species A
 - B. Species B
 - C. Species C
 - D. Species D
30. If acid rain falls into the lake and changes the pH of the water from 6.3 to 5.0, then the species that will increase in concentration is
- A. species A
 - B. species B
 - C. species C
 - D. species D

Use the following information to answer numerical-response question 3.

Test Results Showing the Effects of Seven Different Liquids on Red and Blue Litmus Paper		
	Test I	Test II
Liquid	One drop of liquid is placed on red litmus paper	One drop of liquid is placed on blue litmus paper
Lemon juice	No colour change	Turns red
Ammonia	Turns blue	No colour change
Water	No colour change	No colour change
Liquid W	No colour change	Turns red
Liquid X	Turns blue	No colour change
Liquid Y	No colour change	Turns red
Liquid Z	No colour change	No colour change

Numerical Response

- 3.** For each of the liquids given below, use the number **1** to indicate if the liquid is an acid, the number **2** to indicate if the liquid is neutral, and the number **3** to indicate if the liquid is a base.

Number: _____

Liquid: **Liquid W** **Liquid X** **Liquid Y** **Liquid Z**

(Record all **four digits** of your answer in the numerical-response section on the answer sheet.)

31. When clothes are removed from a clothes dryer, sparks can be seen as the clothes are separated. These sparks are a result of
- A. current electricity
 - B. an electrical discharge
 - C. a buildup of neutral atoms
 - D. anti-static sheets absorbing neutral charges

Use the following information to answer question 32.

Joe watches television for 6.00 hours (21 600 seconds). The input power rating of his television is 200 W. The electrical energy consumed by any electrical device can be calculated using the following formula.

$$E = P \cdot t$$

E = Energy (in joules)
 P = Power (in watts)
 t = Time (in seconds)

32. The total electrical energy consumed by Joe's television is
- A. 33.3 J
 - B. 108 J
 - C. 1.20 kJ
 - D. 4.32 MJ
-
33. Which of the following modifications to an electromagnet will increase its strength?
- A. Using a larger iron core
 - B. Using fewer coils of copper wire
 - C. Increasing the resistance of the iron core
 - D. Decreasing the current passing through the coils of copper wire

Use the following information to answer question 34.

A garage is equipped with two lights and a generator, which are wired in parallel. Each light can be controlled separately, and there is a switch that can turn off both lights at once.

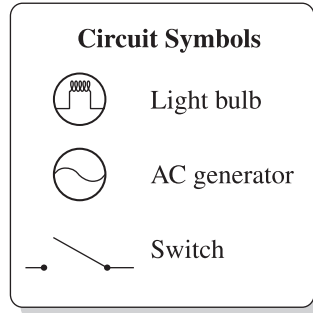

34. Which of the following diagrams represents the circuit described above?

A.

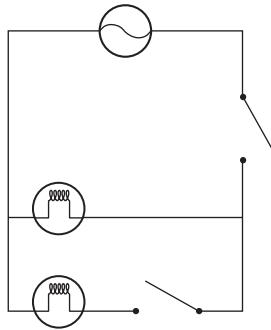

B.

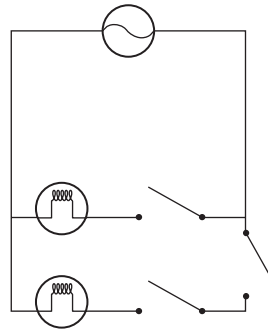

C.

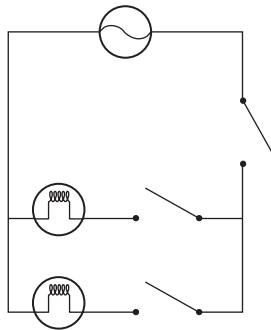

D.

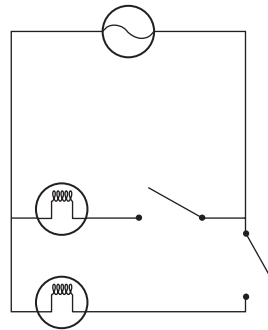

Use the following table to answer question 35.

Year	Coal	Natural Gas	Hydro	Wind	Biomass and Waste	Total
1999	40 276.7	12 126.2	1 453.3	183.1	255.2	54 294.5
2000	40 459.2	15 219.9	1 756.3	71.9	273.8	57 781.1
2001	41 713.3	18 792.9	1 675.4	323.2	282.3	62 787.1
2002	42 541.8	19 462.1	2 188.2	64.6	335.5	64 592.2

35. Which of the following statements is supported by the data in the table above?
- A. The combined production of energy from renewable and non-renewable resources decreases yearly.
 - B. The combined production of energy from renewable and non-renewable resources increases yearly.
 - C. As the generation of electrical energy from non-renewable resources increases, the generation of electrical energy from renewable resources decreases.
 - D. As the generation of electrical energy from renewable resources increases, the generation of electrical energy from non-renewable resources decreases.

Use the following information to answer numerical-response question 4.

In order to produce 100 000 J of heat energy, a hot plate consumes 800 000 J of electrical energy.

Numerical Response

4. To the nearest tenth of a percentage, the efficiency of the hot plate is _____ %.

(Record your answer in the numerical-response section on the answer sheet.)

36. Which of the following wet cells would produce the **highest** voltage?

A.

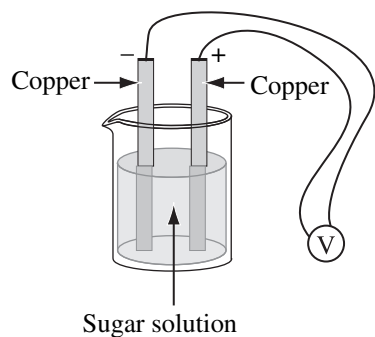

B.

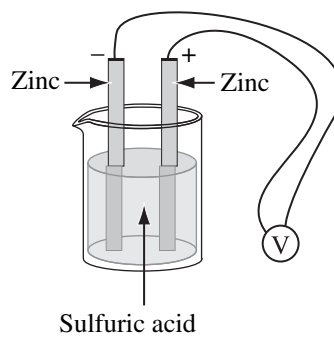

C.

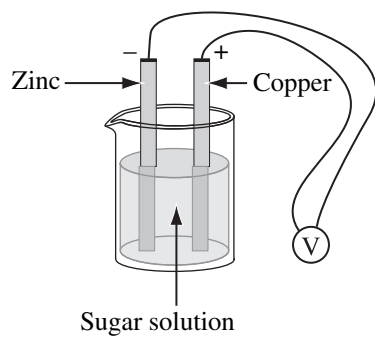

D.

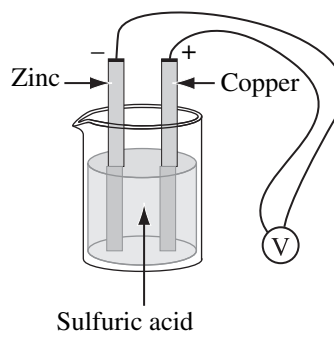

Use the following diagram to answer question 37.

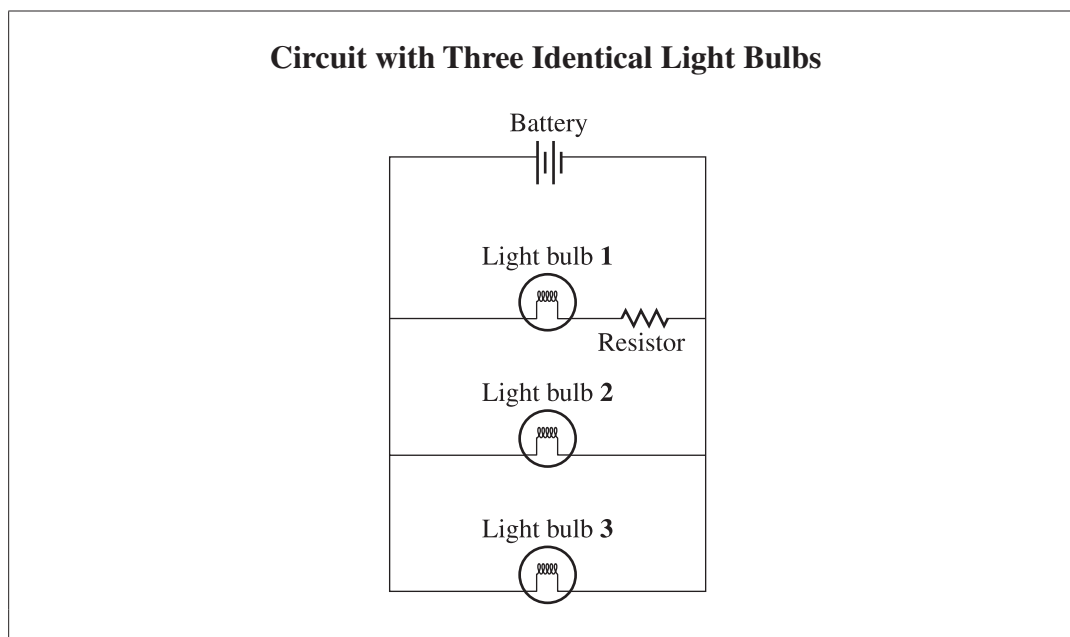

37. Which of the following statements predicts the relative brightness of each of the three light bulbs in the circuit shown above?
- A. Light bulb 1 is dimmer than light bulb 2, which is dimmer than light bulb 3.
 - B. Light bulb 1 is brighter than light bulb 2, which is brighter than light bulb 3.
 - C. Light bulb 1 is dimmer than light bulbs 2 and 3, which both have the same brightness.
 - D. Light bulb 1 is brighter than light bulbs 2 and 3, which both have the same brightness.

Use the following information to answer question 38.

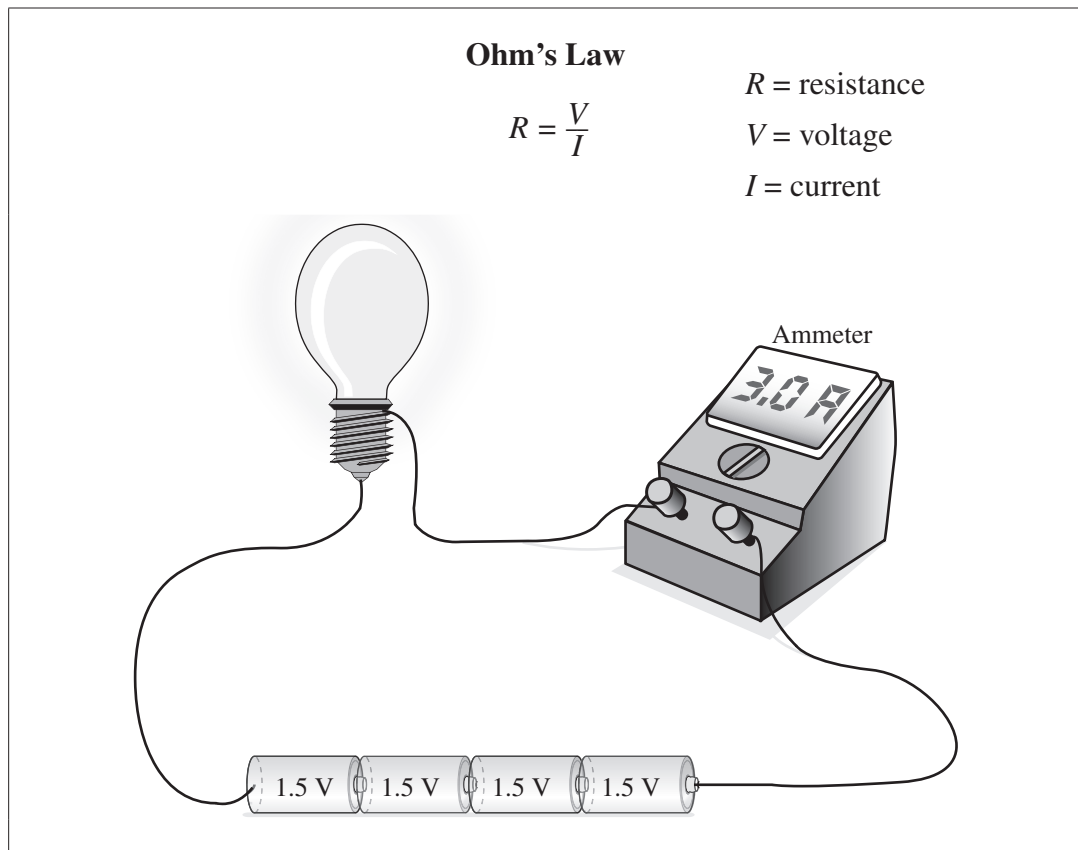

38. The resistance in the circuit shown above is
- A. 2Ω
 - B. 3Ω
 - C. 4Ω
 - D. 6Ω
-
39. Tungsten is used as a filament in some light bulbs because it
- A. allows electrons to flow easily
 - B. allows protons to flow easily
 - C. resists the flow of electrons
 - D. resists the flow of protons

Use the following diagram to answer question 40.

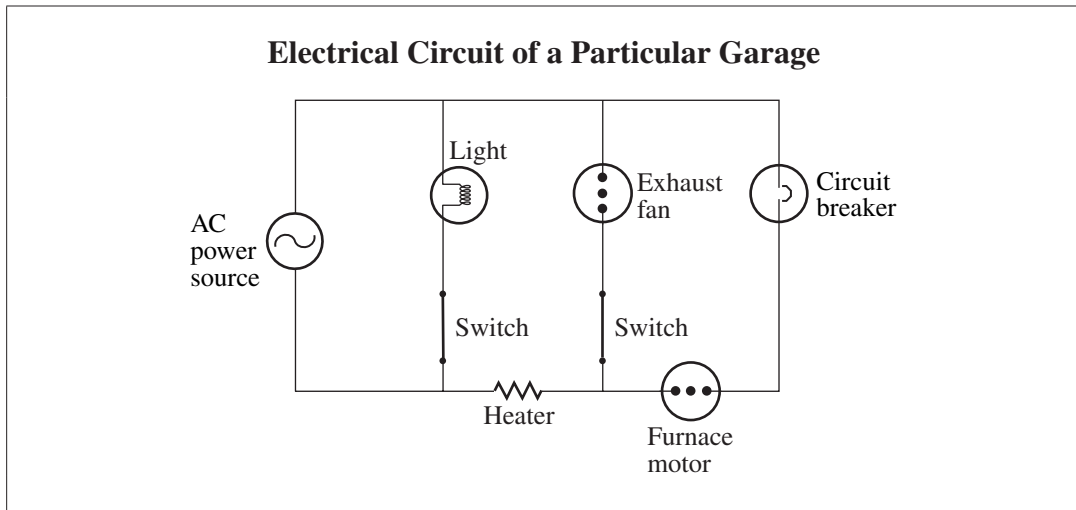

40. Which component in the circuit shown above is protected by the circuit breaker when both switches are closed?
- A. Furnace motor
 - B. Exhaust fan
 - C. Heater
 - D. Light
-

Use the following information to answer question 41.

Astronauts on the International Space Station recycle the water that they use, purify dirty water when necessary, and recover water from the humidity of the air within the station.

41. To manage their water requirements aboard the space station, astronauts do **not** need
- A. processes to purify drinking water
 - B. containers to store large quantities of water
 - C. a system to recover moisture from inside the space station
 - D. solar panels to provide electrical power for the water recycling process

42. Which of the following planets is considered to be terrestrial?
- A. Saturn
 - B. Jupiter
 - C. Uranus
 - D. Mercury

Use the following information to answer question 43.

When satellites become obsolete, they are typically guided back into the atmosphere where they are destroyed. However, in January 2007, China used a ground-based missile to destroy one of its obsolete satellites that was orbiting Earth.

43. If other nations were to use satellite-destruction practices similar to China's, then the **most likely** result would be that
- A. space program costs could decrease
 - B. shuttles could be targeted by missiles
 - C. space junk would decrease, making space exploration easy
 - D. space junk would increase, making space exploration difficult
-
44. A total eclipse of the sun is caused by
- A. Earth passing between the sun and the moon
 - B. Earth spinning on its axis
 - C. the moon passing between the sun and Earth
 - D. the moon spinning on its axis

Use the following information to answer question 45.

Polaris (the North Star) is directly above Earth's geographic North Pole and is the only star in the sky that does not appear to move.

The diagram below shows the location of the Big Dipper relative to Polaris on a spring evening. The locations of the Big Dipper at the same time of day in the summer, autumn, and winter are represented by positions W, X, and Y respectively.

Seasonal Positions of the Big Dipper

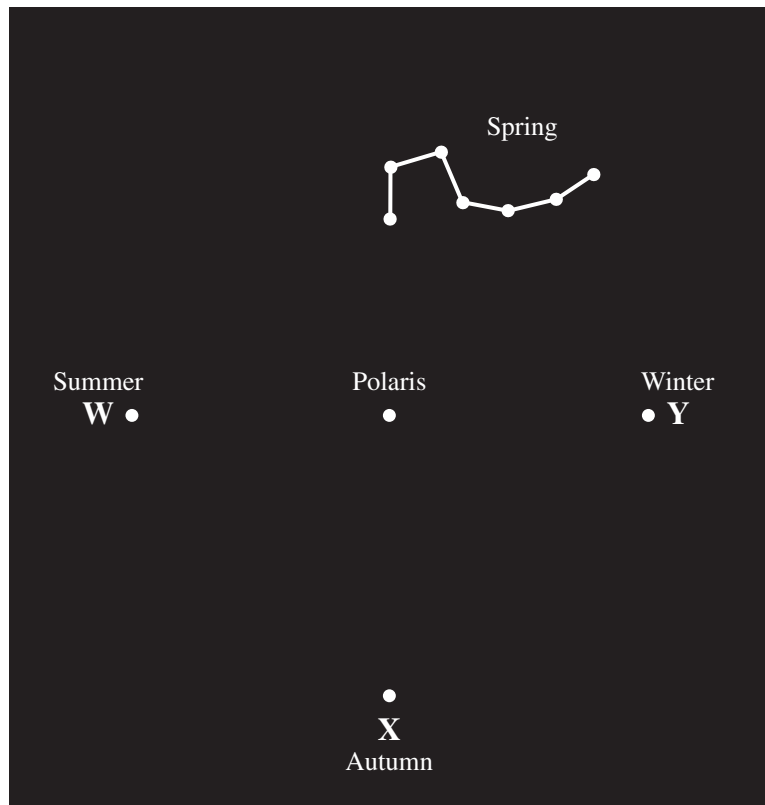

45. Which of the following diagrams shows the orientation of the Big Dipper when viewed on an autumn evening at position X?

A.



B.



C.



D.



46. The Hubble Space Telescope produces clearer images than similar telescopes that are used on Earth because

- A. the Hubble Space Telescope is travelling in a geosynchronous orbit
- B. the Hubble Space Telescope is closer to the stars that it is viewing
- C. there is no interference from Earth's atmosphere in space
- D. there is no air pressure in space

Use the following information to answer question 47.

From a specific point, a star can be found using the coordinates below.

Altitude = 32°

Azimuth = 45°

Peggy wants to find this star in the night sky.

47. To physically locate the star, Peggy must face north, turn *i* , and look *ii* above the horizon.

The statement above is completed by the information in row

Row	<i>i</i>	<i>ii</i>
A.	clockwise 45°	32°
B.	counterclockwise 45°	32°
C.	clockwise 32°	45°
D.	counterclockwise 32°	45°

Use the following list to answer numerical-response question 5.

Parts of the Universe

- 1 Earth
- 2 Milky Way
- 3 Solar system
- 4 Sun

Numerical Response

5. List the parts of the universe given above in order from the part with the smallest diameter to the part with the largest diameter.

**Smallest
diameter**

**Largest
diameter**

(Record all **four digits** of your answer in the numerical-response section on the answer sheet.)

Use the following diagram to answer question 48.

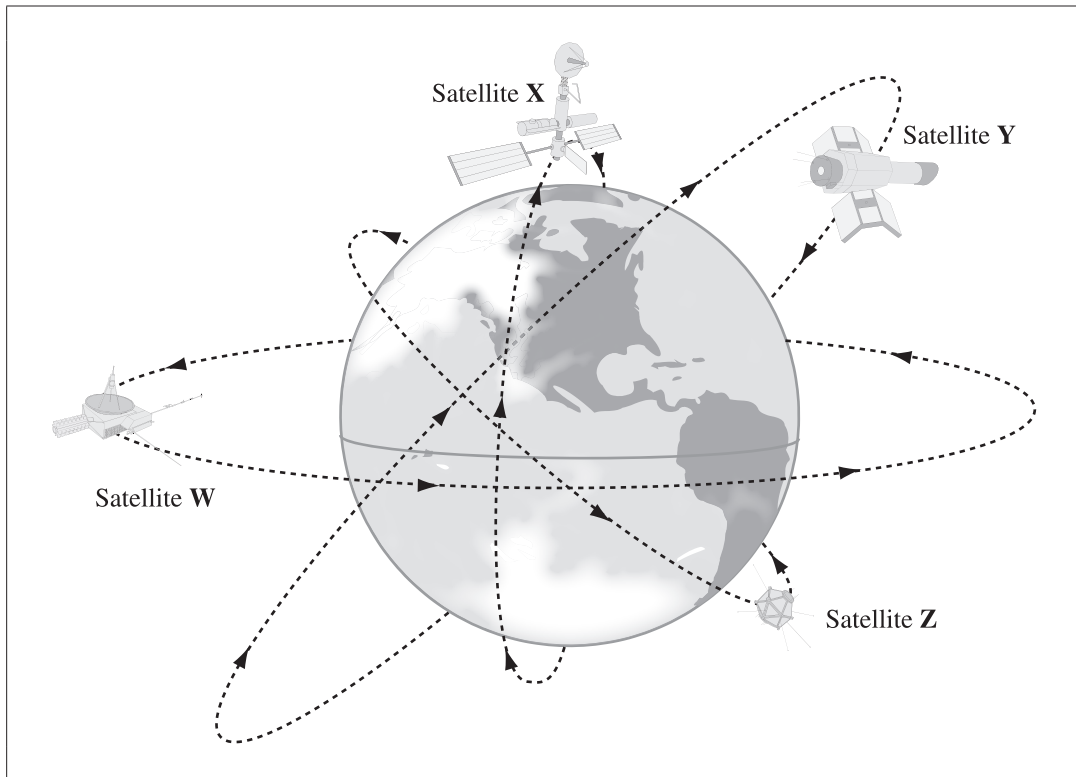

48. Which pair of satellites in the diagram above can transmit signals over the greatest area of Earth's surface?
- A. Satellites W and Y
 - B. Satellites W and Z
 - C. Satellites X and Y
 - D. Satellites X and Z

49. Astronomers can use a spectroscope to
- A. determine the composition of stars
 - B. map the location of celestial bodies in the sky
 - C. observe celestial bodies that were previously invisible
 - D. see images in space that are not distorted by Earth's atmosphere

Use the following illustration to answer question 50.

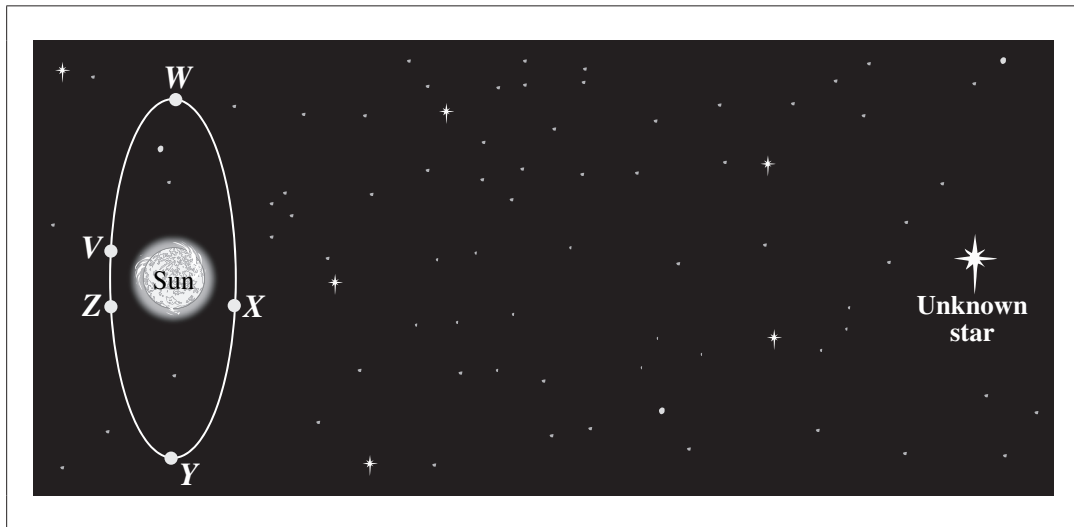

50. The **best** baseline for triangulation to determine the distance between the unknown star and the sun shown above will be established when Earth is in positions W and
- A. V
 - B. X
 - C. Y
 - D. Z

2008 Test Blueprint and Item Descriptions

The following blueprint shows the reporting categories and topics by which questions were classified on the 2008 Grade 9 Science Achievement Test.

Topic	Question Distribution by Reporting Category		Number (Percentage) of Questions
	Knowledge	Skills	
Biological Diversity	5 (1, 2, 5, 9, NR1)	6 (3, 4, 6, 7, 8, 10)	11 Questions (20% of Total Test)
Matter and Chemical Change	5 (11, 15, 16, 17, 18)	6 (12, 13, 14, 19, 20, NR2)	11 Questions (20% of Total Test)
Environmental Chemistry	4 (21, 22, 24, 26)	7 (23, 25, 27, 28, 29, 30, NR3)	11 Questions (20% of Total Test)
Electrical Principles and Technologies	3 (31, 33, 39)	8 (32, 34, 35, 36, 37, 38, 40, NR4)	11 Questions (20% of Total Test)
Space Exploration	5 (42, 44, 46, 49, NR5)	6 (41, 43, 45, 47, 48, 50)	11 Questions (20% of Total Test)
Number (Percentage) of Questions	22 Questions (40% of Total Test)	33 Questions (60% of Total Test)	Total Test 55 Questions (100%)

The table below provides information about each question on the 2008 test: the keyed response, the difficulty of the item (the percentage of students who answered the question correctly), the reporting category, the topic, and the item description.

Question	Reporting Category	Key	Difficulty (%)	Topic	Item Description
1	Knowledge	D	78.9	Biological Diversity	Identify an advantage of asexual reproduction
2	Knowledge	B	70.4	Biological Diversity	Identify where fertilization occurs during the stages of sexual reproduction
3	Skills	B	52.2	Biological Diversity	Determine the effect of a change in one population on another given a description of an ecosystem
4	Skills	B	47.3	Biological Diversity	Analyze a graph to identify the niche of a species
5	Knowledge	A	74.5	Biological Diversity	Identify a trait that is influenced by environmental factors
6	Skills	D	61.2	Biological Diversity	Differentiate between generalist and specialist species using two distribution maps
7	Skills	D	68.0	Biological Diversity	Analyze a map of North and South America to determine which region contains the most biological diversity
8	Skills	B	46.2	Biological Diversity	Determine the gene pair combinations of a father and mother based on the children's hair colours
9	Knowledge	C	80.6	Biological Diversity	Identify the part of a cell that carries information about heritable traits
10	Skills	B	50.8	Biological Diversity	Analyze and determine the flawed biological process that results in a chromosome disorder
11	Knowledge	A	68.0	Matter & Chemical Change	Recall that oxygen is a reactant in all corrosion and combustion reactions
12	Skills	D	74.9	Matter & Chemical Change	Synthesize information from a table of properties to describe the conductivity of two elements
13	Skills	B	76.6	Matter & Chemical Change	Using the IUPAC format, name a molecular compound
14	Skills	D	77.9	Matter & Chemical Change	Use the periodic table to distinguish a common property of elements that are in the same group

Question	Reporting Category	Key	Difficulty (%)	Topic	Item Description
15	Knowledge	D	84.5	Matter & Chemical Change	Given a chemical formula, recognize the elements that are present and their quantities
16	Knowledge	B	54.9	Matter & Chemical Change	Identify an example of a chemical change
17	Knowledge	D	34.4	Matter & Chemical Change	Recognize the type of compound that is formed when two non-metallic elements are combined
18	Knowledge	A	54.1	Matter & Chemical Change	Identify a substance that is a solution
19	Skills	C	67.5	Matter & Chemical Change	Analyze data from a table to determine which substance reacts most readily with an acid
20	Skills	C	66.9	Matter & Chemical Change	Infer the chemical formula of a molecular model by analyzing other molecular models
21	Knowledge	A	55.2	Environmental Chemistry	Recognize an example of an inorganic substance
22	Knowledge	C	73.7	Environmental Chemistry	Identify the statement that best defines the term LD50
23	Skills	C	55.9	Environmental Chemistry	Analyze a graph of two populations over time to predict which graph would represent dissolved oxygen concentrations over time
24	Knowledge	D	74.8	Environmental Chemistry	Recognize the manipulated variable in an experiment
25	Skills	A	63.7	Environmental Chemistry	Formulate a conclusion by interpreting experimental results
26	Knowledge	C	69.2	Environmental Chemistry	Recognize a substance that can be synthesized by plants
27	Skills	B	79.7	Environmental Chemistry	Analyze a graph to make an inference regarding the effect of pesticides on a species over time
28	Skills	B	65.1	Environmental Chemistry	Analyze a graph to determine which species is most sensitive to changing pH levels
29	Skills	C	78.4	Environmental Chemistry	Analyze a graph and apply knowledge of the pH scale to determine the concentration of a species

Question	Reporting Category	Key	Difficulty (%)	Topic	Item Description
30	Skills	C	51.9	Environmental Chemistry	Analyze a graph to determine the effects of acidity on four aquatic species
31	Knowledge	B	75.6	Electrical Principles & Technologies	Recognize an example of an electrical discharge
32	Skills	D	69.1	Electrical Principles & Technologies	Calculate electrical energy given power and time
33	Knowledge	A	61.4	Electrical Principles & Technologies	Recognize a means by which the strength of an electromagnet can be increased
34	Skills	C	70.4	Electrical Principles & Technologies	Determine the correct circuit diagram based on given criteria
35	Skills	B	72.4	Electrical Principles & Technologies	Construct an inference based on raw data from a table
36	Skills	D	82.9	Electrical Principles & Technologies	Compare different configurations of electrodes and electrolytes to determine which one produces the greatest voltage
37	Skills	C	66.1	Electrical Principles & Technologies	Predict the relative brightness of three light bulbs in a parallel circuit when a resistor is added to one part of the circuit
38	Skills	A	80.2	Electrical Principles & Technologies	Determine the resistance in an illustrated series circuit
39	Knowledge	C	35.7	Electrical Principles & Technologies	Recognize the reason that tungsten is used in light bulbs
40	Skills	A	73.1	Electrical Principles & Technologies	Interpret a circuit diagram to determine which component is protected by a circuit breaker
41	Skills	B	54.3	Space Exploration	Evaluate water management needs and strategies on the International Space Station
42	Knowledge	D	56.8	Space Exploration	Recognize a planet that is terrestrial
43	Skills	D	74.9	Space Exploration	Predict the most likely effect of a new technology used for satellite disposal

Question	Reporting Category	Key	Difficulty (%)	Topic	Item Description
44	Knowledge	C	79.2	Space Exploration	Determine the positions of celestial bodies that produce an eclipse of the sun
45	Skills	A	63.8	Space Exploration	Describe the position of celestial bodies at a particular time of year
46	Knowledge	C	68.6	Space Exploration	Identify the reason why a telescope positioned in a space environment produces clearer images than a surface telescope
47	Skills	A	57.9	Space Exploration	Describe how to use angular coordinates to locate the position of a star
48	Skills	A	69.1	Space Exploration	Analyze a diagram of satellite orbits to determine which satellites can transmit signals over a greater area
49	Knowledge	A	55.1	Space Exploration	Identify the type of information that astronomers obtain from spectral analysis
50	Skills	C	74.0	Space Exploration	Determine which two points combine to make the best baseline for triangulation
NR1	Knowledge	122	67.2	Biological Diversity	Identify traits as examples of either discrete or continuous variation
NR2	Skills	60.6	66.5	Matter & Chemical Change	Apply knowledge of the law of conservation of mass to determine the mass of a reactant
NR3	Skills	1312	68.2	Environmental Chemistry	Use the results of an experiment involving indicators to classify substances as acidic, basic, or neutral
NR4	Skills	12.5	47.7	Electrical Principles & Technologies	Calculate the efficiency of a device given the heat energy produced and the electrical energy consumed
NR5	Knowledge	1432	52.2	Space Exploration	Order the diameter of four celestial bodies from smallest to largest